

KN2C 2015 Team Description

Milad Abaierad, Mina Mobahi, Fatemeh Ghofrani, Vida Zolghadr, Mohsen Raoufi
Sara Biglari, Mohammad Reza Karimi Dastjerdi, Mohammad Amin Kashi

K.N.Toosi University Of Technology, Faculty of Electrical Engineering, Advanced
Robotics & Automated Systems(Aras) Lab, Tehran, Iran
info@kn2c.ir

www.kn2c.ir

Abstract. KN2C Small Size Soccer team, with more than five years of experience, is planning to participate in 2015 world games. In this paper we present an overview of KN2C small size team.

1 Introduction

“KN2C” small size soccer team, founded in 2009, is part of Advanced Robotics and Automated Systems (Aras) Lab. The purpose of this team is to design and build small size soccer robots for participating in International Robocup competitions. This team has participated in four Iran Open Small Size League competitions. In this paper we first introduce our new electrical system. Our robots' Mechanical system will be discussed in section 3 and software and control will be covered in section 4.



Figure 1 Our Robots

2 Electronics

Electronic design has been thoroughly changed since last year. Each robot consists of a main board, four driver boards and a kick board, each of which will be introduced in the following.

2.1 Main Board

In each main board an ATXMega64A3U Microcontroller (from AVR Family) is used to receive data from computer and process part of data in robots. This 8bit Microcontroller has a low-power consumption. The internal architecture of this microcontroller is RISC, with 1MIPSPer MHz processing power and 32MHz operating frequency.

Considering past version of robots problems, such as its imbalance operation because of using four ATmega88 Microcontrollers to drive motors, we decided to use a FPGA XCS400 processor from Xilinx Company instead. FPGA processor, due to its ability of parallel processing, is a good replacement for driving motors and implementing the controller loop. It receives the speed of each motor from Microcontroller.

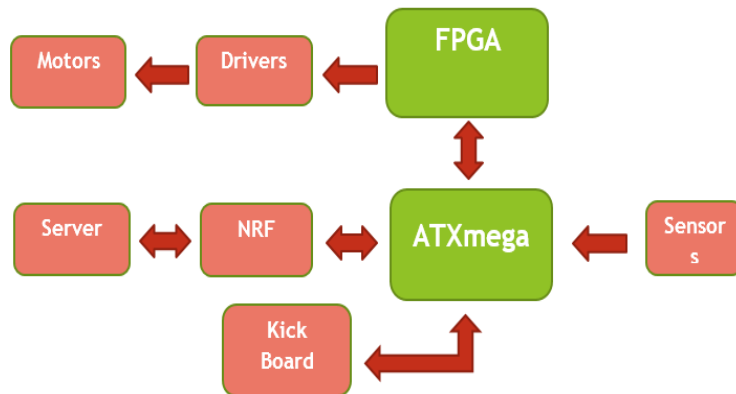

Figure 2 block diagram of the electrical system.

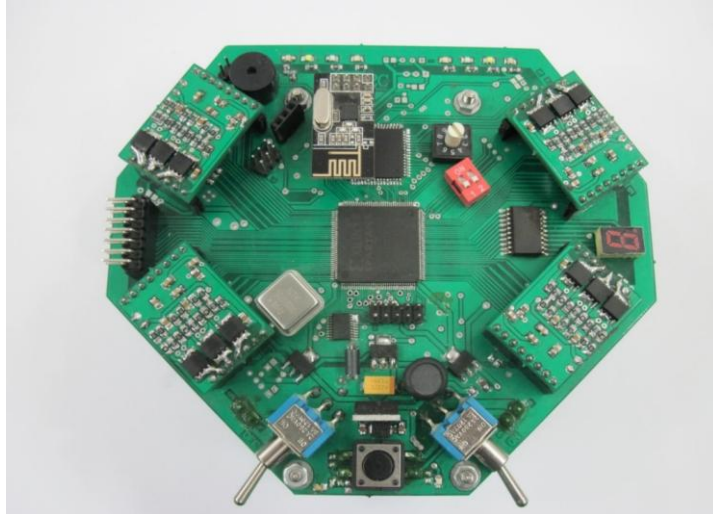

Figure 3 Main Board

2.1 Motor Drivers

Four BLDC Motors (Maxon EC45 Flat Motor) 30W is driven by 4 inverter boards using hall.



Figure 4 Motor Drivers

2.2 Wireless communication

nRF24L01P modules are used for wireless communication between computer and robots. Operation frequency of this module is 2.4GHz and could be changed in range of 100MHz. This module works in SPI communication protocol. In this communication, motors speed, kick speed and robot ID are sent from computer to robots. Battery voltage and kick sensor signals are sent from robots to computer.

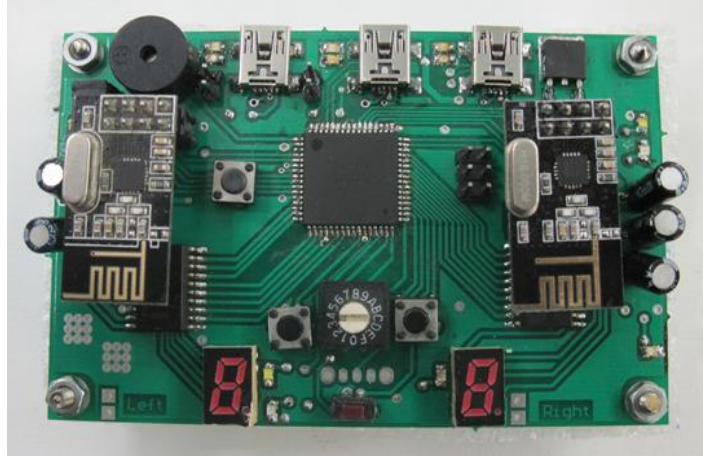

Figure 5 Wireless Board

2.3 Kick Circuit

In kick circuit in order to achieve the proper speed, two parallel capacitors (200V, 2200uF) are charged to the desired voltage level using a Boost circuit. Then the microcontroller from the main board produces PWM wave to give the order of straight or chip kick.

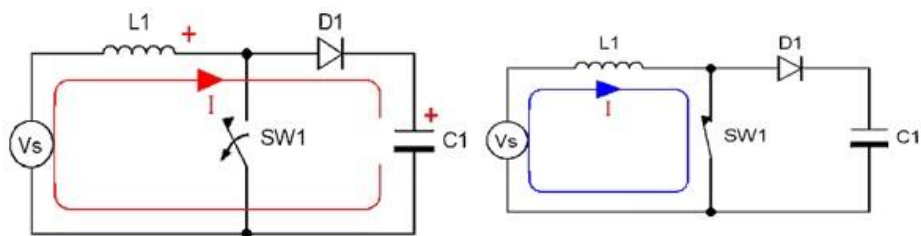

Figure 6 Boost Circuit

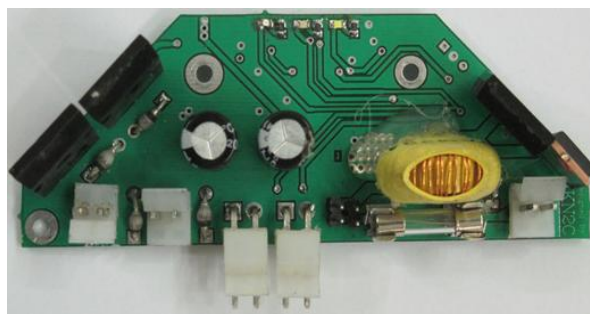

Figure 7 Kicker Board

3 Mechanics

This year no changes have been made to mechanics [1]. Robots have 4 Maxon EC45 Flat motors. These motors are 12V, 4200rpm and 30W. Diameter of the motors is 45mm and their length (including the length of encoders) is 4cm. With these dimensions it was simple to place four motors in each robot. Motors Gears are placed inside the wheels with 8.3:1 ratio. Considering these, our robots are capable of moving forward up to 3.5 m/s.

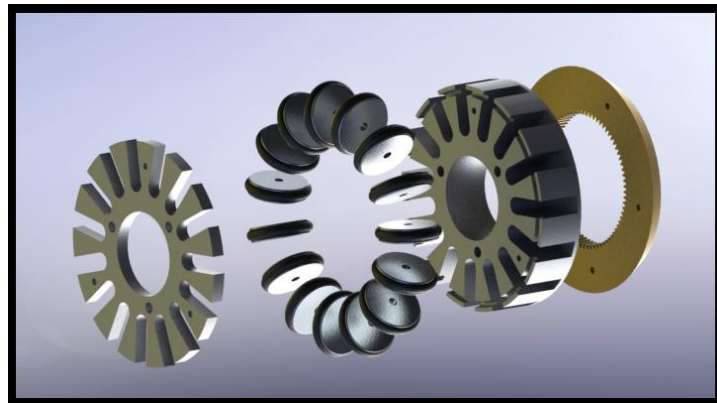

Figure 8 3D figure of the robot wheel

Both direct and chip kicks are designed in the robots. For direct kick we used a solenoid with 8 round of 23AWG wire and for chip kick we used 6 round of the same wire. This way robots are able to kick the ball up to 8 m/s in direct direction and 2.5m distance with chip kick.

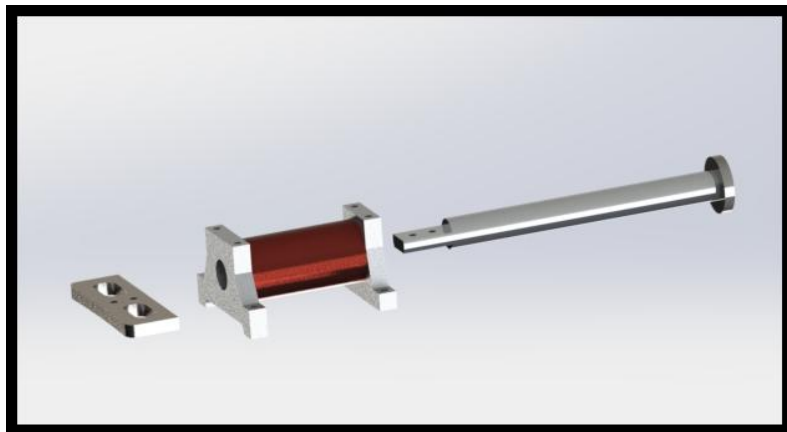

Figure 9 Direct kick system

4 Software

We write our codes in C++ Programming language using Qt framework. The decision making system has been designed using STP Architecture [2]. In Fig.10 a view of software system is shown. We have two UDP sockets. One of them for receiving SSL vision data and another one for receiving referee commands. After data filtering, a world model generated by filtered input data. The world model is given to AI for deciding the way of play. After AI took its decision, it uses Navigation and controller modules for generating final commands which will be sent to each robot over wireless system.

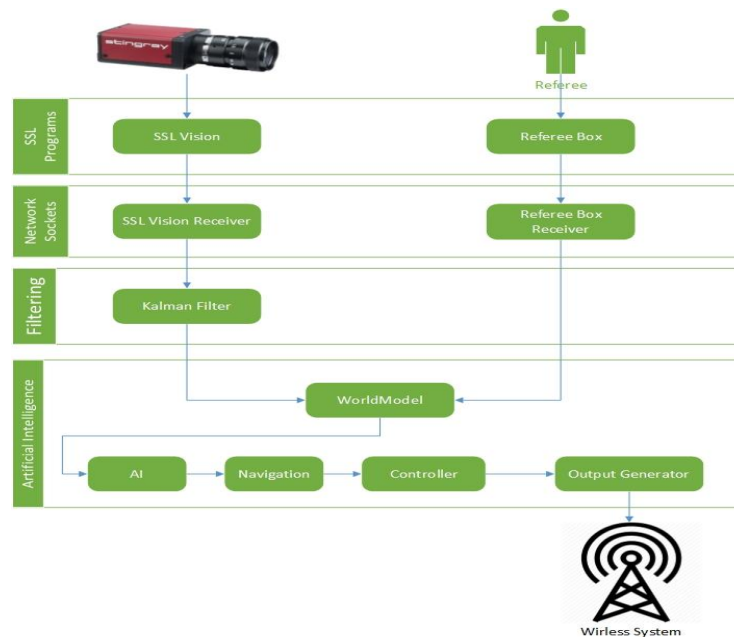

Figure 10 Overview of Software System

4.1 Navigation

Our navigation system is based on A* search algorithm. A* uses a best-first search and finds a least-cost path from a given initial node to one goal node. For each robot we give six points around it as initial nodes and desired position as goal node.

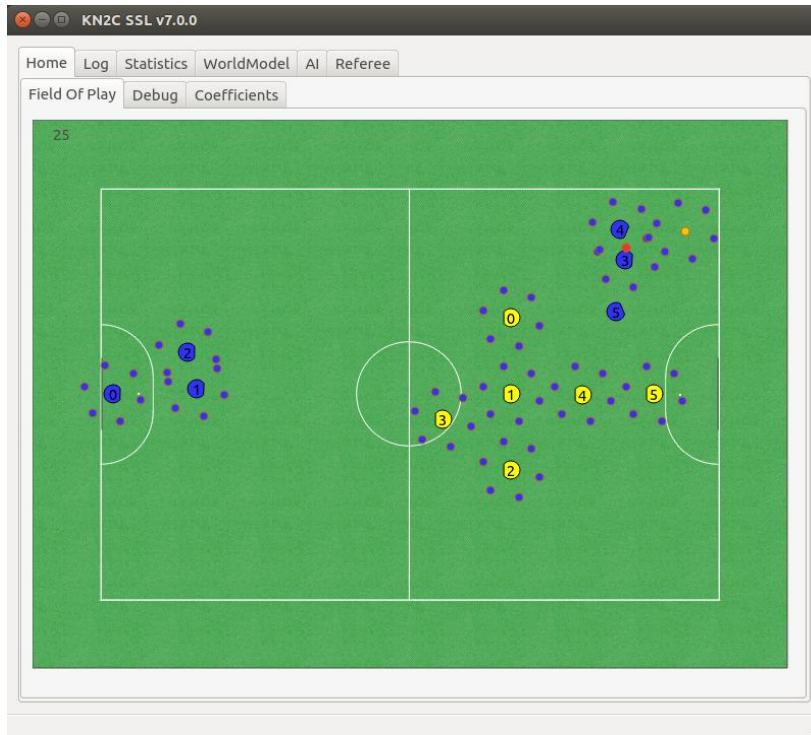

Figure 11 Output of A* Algorithm

4.2 Control

Controlling of each robot consists of two stages. First stage controls robot's motions and direction, its speed and increase its accuracy in positioning. Feedback of vision feeds this stage of control system.

The output of this controller is X and Y speed of the robot.

Second controller is assigned to reach the set point which is generated from output of first controller. This controller, controls the speed of the wheels.

In second controller we've used a PD core controller in addition of a coefficient tuning system (CTS). Which adjust proportional gain and derivative gain.

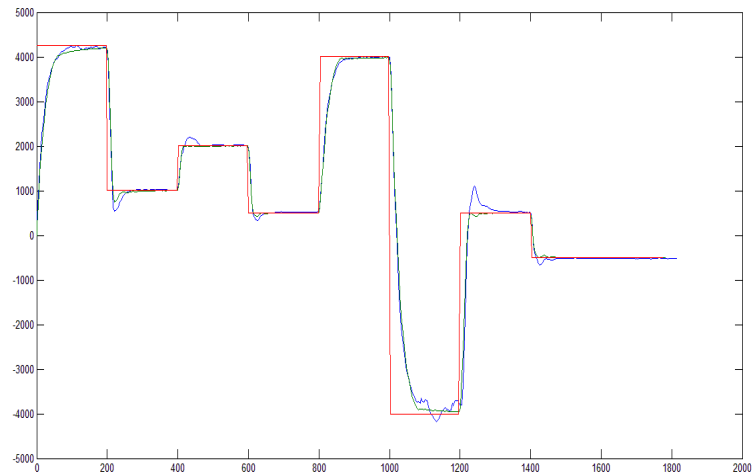

Figure 12 PID controller vs PD core controller with CTS

This figure shows differences of a fairly perfect tuned PID controller (blue) and PD core controller with CTS (green) (setpoint red).

Feedback of second stage is obtained from Hall Effect sensors.

Some important numbers in our controlling system:

- Refresh rate of vision: About 15 ms
- First controller stage loop time: About 15 ms
- Data transferring delay time: about 3ms
- Second controller stage loop time: about 1 ms

One important point about vision feedback is that if here we have a long delay in receiving data from camera then in combination of rotation and displacement speeds of a robot in a certain direction, say x, then we see a diversion in direction of displacement.(more rotational speed ,more skewed direction)

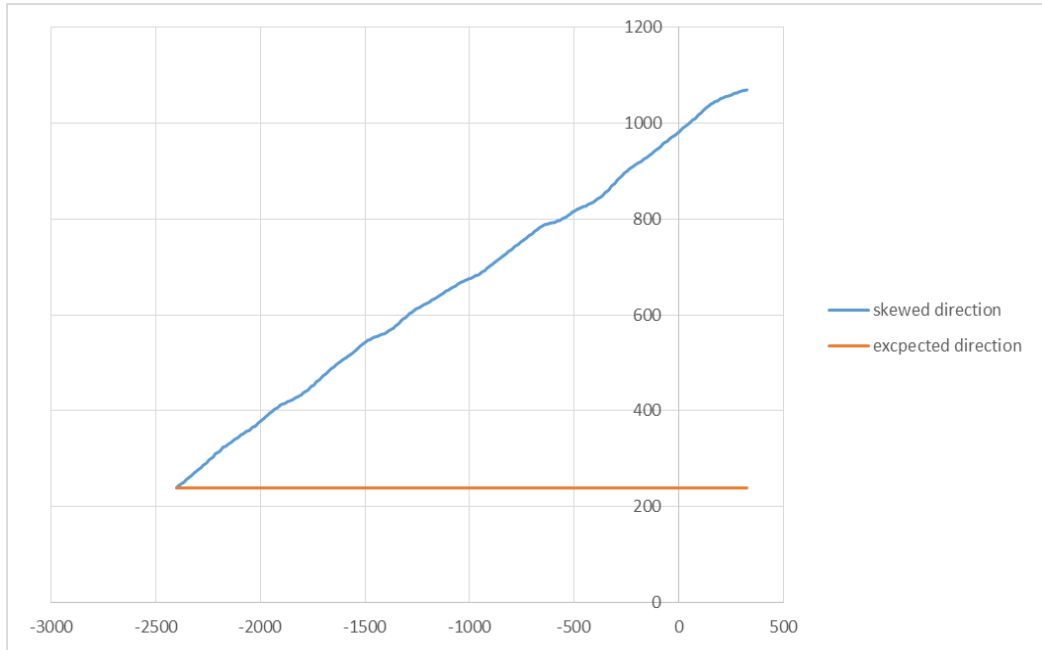

Figure 13 Diversion in direction of displacement

4.3 User Interface

Although our last UI has the ability of show each robot's position, but we realized that it's not enough for debugging our algorithms. So we add new features to Our UI for More Visualizing. We visualize these options in our new UI:

- Output of Navigation Algorithm
- Offensive positions for each robot
- Marked opposite robots
- Goal opportunity for each attacker
- ...

4.4 Simulation

Robot software development usually requires a full functional real robot, however due to the hardware problems which experimental robots always suffer from, it's hard to design software during hardware development process. In addition, when a full functional real robot exists, constraints like cost, maximum operation time and possible damages slow down the software development process. Robot simulators can overcome such problems. According to these problems, we use grSim for simulate the SSL games.

grSim is a multi-robot simulation environment designed especially for RoboCup small size soccer robot domain. It is able to completely simulate and visualize a robot soccer game with full details. Teams can communicate with the simulator in the same way they communicate with real world, except the commands should be sent to the simulator via network instead of radio connections to the robots.[3]

References

1. Milad Abaierad, Mina Mobahi, Fatemeh Ghofrani, Vida Zolghadr, Mohsen Raoufi, Sara Biglari. "KN2C 2014 Team Description." In: Proceedings of Robocup 2014.
2. Browning, Brett, James Bruce, Michael Bowling, and Manuela Veloso. "STP: Skills, tactics, and plays for multi-robot control in adversarial environments." Proceedings of the Institution of Mechanical Engineers, Part I: Journal of Systems and Control Engineering 219, no. 1 (2005): 33-52.
3. Valiallah Monajjemi, Ali Koochakzadeh, and Saeed Shiry Ghidary.: "grSim - RoboCup Small Size Robot Soccer Simulator". Computer Engineering and Information Technology Department, Amirkabir University of Technology