

Kavak 2012 Team Description Paper

Mehdi Akbari¹, Atefeh AghaBabae³, Ali Mahboobi²,
Fateme Mosleh¹, Maryam Rezapour², Mehdi Shamsi¹

¹ Department of Computer Engineering

² Department of Computer Science

³ Department of Physics

Tarbiat Moallem University of Tehran

Mag8968@gmail.com

Abstract. This paper is aimed to describe the Robocup small size team, Kavak. The robots mechanism is designed according to Robocup 2012 rules in order to take part in the Robocup 2012 Competition. This paper will discuss all three parts that we worked on, including mechanical part, electrical part and software.

1 Introduction

Kavak robotic association of Tarbiat Moallem University was established in 2008 after a team of named university became first in Europe New Idea competitions.

Members of Kavak small size team gathered in 2010 from faculties of Physics, Computer Engineering and Computer Science in order to improve their skills in electronics, mechanics and artificial intelligence and participate in different competitions. Here is an overview of what we have done during this time. This paper presents Electrical design, Mechanical design and AI system in order.

Figure 1. Our Robots



2 Electrical Design

The electrical system consists of 4 fundamental parts, the main board (consists of processor, capacitors, batteries, Voltage converter, ball detectors and etc.), the kick module, the motor drivers system and the wireless communication. The diagram of electrical system and their communications is shown in Fig 1.

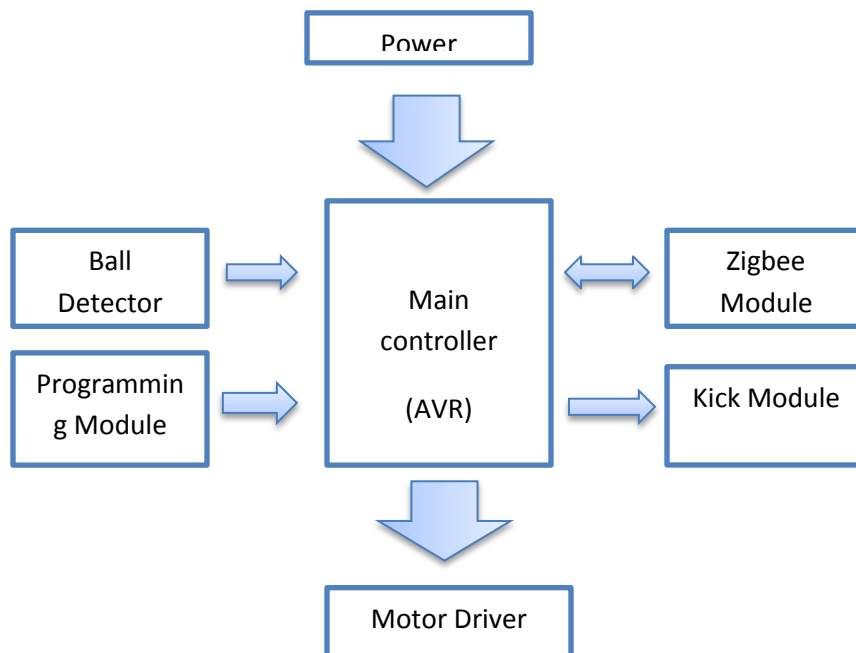

Figure 2. The electrical system's diagram

2.1 Microcontroller

ATmega-32 (AVR family) is the Microcontroller which is used to process data in robots. The microcontroller gets Zigbee (wireless module) data with the USART protocol and then sends orders to mechanical parts. This part does not decide for any responses and only transmits orders (like kicking order, motion order, etc.) to the respective parts. We want to use ATXmega64A3 (Xmega family is a new family of AVR which has a better performance) for Iran Open and Robocup after we test our boards and get good responses.

2.2 Motor drivers

Each motor is operated with L6203 that is a full bridge driver. The DMOS output transistors can operate at supply voltages up to 42V and efficiently at high switching speeds and speed of motors can be controlled with PWM pulse of microcontroller.

2.3 Wireless communication

For this part of robot for wireless communication with computers we use X-Bee with port number (4142). Although working with this module is complicated but we decided to use it for some reason, such as: being able to transfer data in large distances and having fast speed in transmitting data.

X-Bee is built on top of the IEEE 802.15.4 protocol and uses only +3.3 volts. The regulator usually has a different pin arrangement: G-O-I.

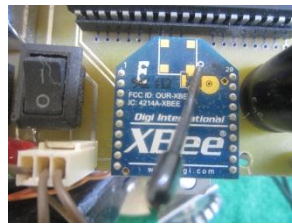

Figure 3. X-bee

2.4 Shoot system

One of the simple ways for robots kicking is using shoot circuit with capacitors. In this circuit we charge capacitors in parallel mode with using relay. Then circuit will be switched and capacitors will be discharged in serial mode and we connect it to solenoid.[1]

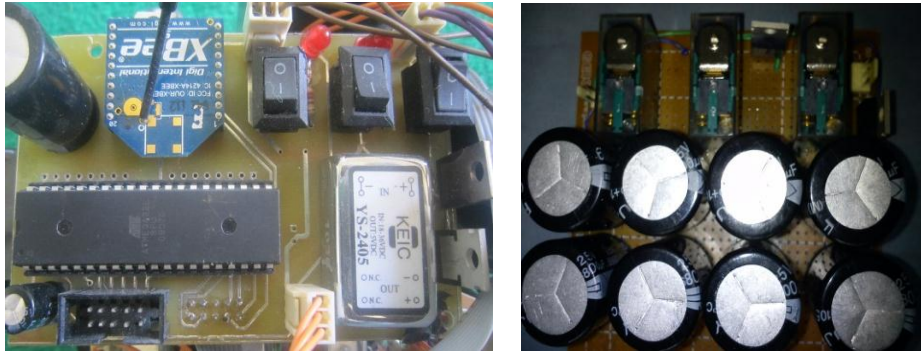

Figure 4. a.Main board b.Shoot circuit

2.4.1 Non-isolating converters:

The non-isolating type of converter is generally used where the voltage needs to be stepped up or down by a relatively small ratio (say less than 4:1), and there is no problem with the output and input having no dielectric isolation. Examples are 24V/12V voltage reducers, 5V/3V reducers and 1.5V/5V step-up converters. There are five main types of converter in this non-isolating group, usually called the buck, boost, buck-boost, Cuk and charge-pump converters. The buck converter is used for voltage step-down/reduction, while the boost converter is used for voltage step-up. The buck-boost and Cuk converters can be used for either step-down or step-up, but they are essentially voltage polarity reversers/inverters as well. (The Cuk converter is named after its originator, Slobodan Cuk of Cal Tech University in California.)

The charge-pump converter is used for either voltage step-up or voltage inversion, but only in relatively low power applications.

We choose the boost converter for our shooting system.

2.4.2 The boost converter

The boost converter is perhaps the simplest of all switched mode converters. It uses a single inductor without the need for "difficult" transformers. Its working can best be explained with the simplified circuit diagram given in Here the transistor is represented by an ideal switch and the control circuitry has been omitted. A high voltage capacitor C is used to buffer the output voltage. In a typical configuration the input voltage would be something like $V_{bat}=12V$ and the output voltage $V_{out}=180V$.

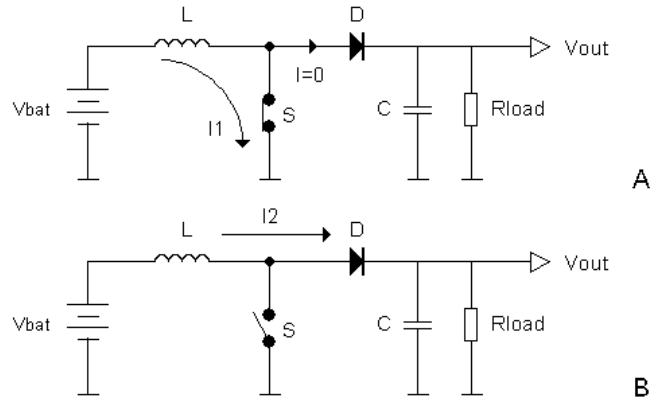

By balancing the amount of power stored in the inductor to the amount of power dissipated in the load it is possible to calculate the output voltage of the boost converter.

Every second the amount of power dissipated by the load is:

$$\frac{V_{out}^2}{R_{load}} \quad (J) \quad [1]$$

If T is the total cycle time, and x the fraction of T that the switch is closed, then the maximum current in the inductor is:

$$I_{peak} = \frac{V_{bat}}{L} xT$$

The energy per package delivered by the inductor is:

$$\frac{1}{2} LI_{peak}^2 = \frac{1}{2} \frac{V_{bat}^2}{L} x^2 T^2$$

In one second $f=1/T$ packages are delivered so the amount of energy delivered per second is:

$$\frac{1}{2} \frac{V_{bat}^2}{L} x^2 T \quad (J) \quad [2]$$

Since in steady-state the amount of energy delivered should equal the amount of energy used $[1]=[2]$:

$$\frac{1}{2} \frac{V_{bat}^2}{L} x^2 T = \frac{V_{out}^2}{R_{load}}$$

$$V_{out} = V_{bat} x \sqrt{\frac{RT}{2L}}$$

3 Mechanical Design

Our robots mechanical system has two layers. The first layer consists of motors, wheels and batteries, and the second one consists of kicking system and electronic boards.

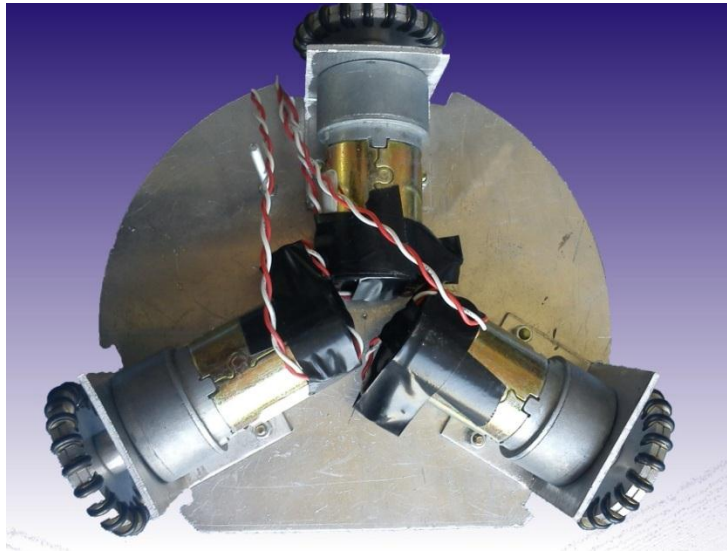

Figure 5. Mechanical design

3.1 Driving system

This part consists of three driving motor which are placed with the angle of 120° with each other, and are connected to omnidirectional wheels.

Motor drivers are the product of Buhler Company in Germany and Micro Motor in Italy. Motors characteristics are listed below:

type	NOMINAL VOLTAGE	GEAR	MAXIMUM TORQUE	SPEED		CURRENT
		RATIO		NO LOAD	AT MAX TORQUE	
	v	TO:1	Ncm	rpm		mA
Micro motor	12	10	5	660	460	140
Buhler	24	9.9	9.8	500	335	300

Table 1. Motors characteristics

Our robots have omnidirectional wheels with following characteristics:

Number of wheels	Wheels diameter	Wheels thickness	Rings diameter	Number of rings
3	50	5	8	20

Table 2. Wheels characteristics

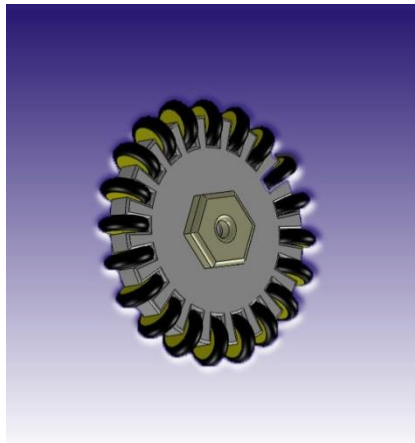

Figure 6. Omnidirectional Wheels

3.2 Kicking system

We have designed two kind of kicking system and based on the robots usability each one of them is placed on the robots:

1. Magnetic kicking system
2. Spring based Kicking system

3.2.1. Magnetic kicking system

In this structure, an iron core is placed near a solenoid and from another direction it is connected to two hinge and lever.

With applying voltage, a magnetic field is created in the circuit and it causes the core to be pulled into solenoid and finally moving of hinge and lever.

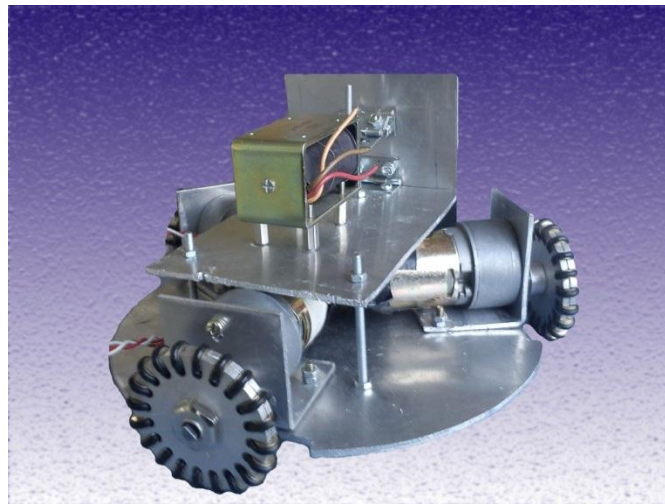
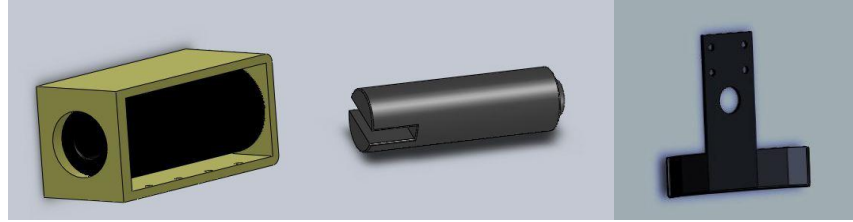

Figure 7. Magnetic kick system

3.2.2. Spring based kicking system

This structure consists of a gearbox motor which is connected to two cogwheels and these cogwheels are connected to a spring themselves. With spinning of cogwheels, the spring is pulled and a large amount of energy is stored in it. Then with sudden release of this amount of energy, spring moves backward and lever moves forward.

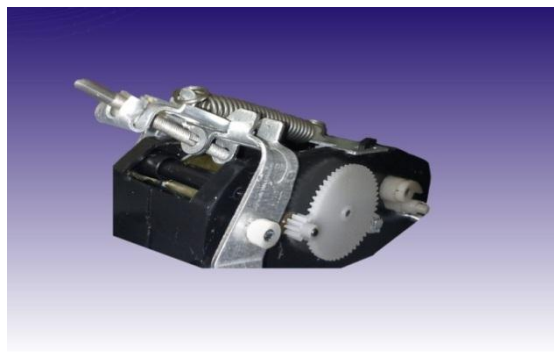

Figure 8. Spring based kick system

4 Software

4.1 Vision System

Since 2010 RoboCup Small Size teams should have used an open source shared vision system called SSL-Vision. Due to this decision of Small Size committee, a group from Small Size League, volunteered to develop the image processing algorithms. The Geometric parameters which were generated by SSL-Vision are very useful for our decision making. [2][3]

4.2 Predicting and Update of World Model

Many parameters such as noise on wireless communication, delay in sending images from camera to processing part, delay in mechanical operations and processing algorithms cause our data which is the state of ball and robots not to be accurate. To avoid this, we decided to use Kalman Filter predictor. Hence Kalman Filter estimates object states in linear system, in some cases like ball positions we used Extended Kalman Filter. [4]

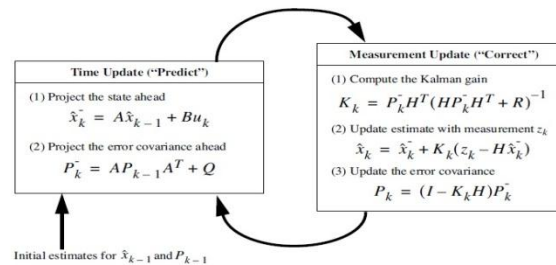

Figure 9. A complete picture of the operation of the Kalman filter

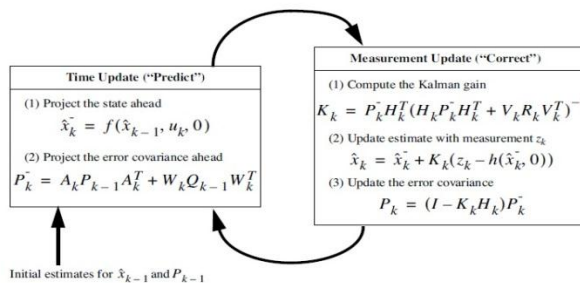

Figure 10. A complete picture of the operation of the extended Kalman filter

4.3 Planning

In this Layer, according to the updated coordinations by Kalman Filter, current state of the game and referee, our algorithm has four choice to make for robots in the field, passing the ball, going through the specific coordination, kicking, dribbling or standing in the current mode.

References

1. <http://www.williamson-labs.com/555-tutorial.html>
2. Stefan Zickler, Tim Laue, Oliver Birbach, Mahisorn Wongphati, and Manuela Veloso, “SSL-Vision: The Shared Vision System for the RoboCup Small Size League”
3. SSL-Vision Developer Team: RoboCup Small Size League Shared Vision System Project Home. <http://code.google.com/p/ssl-vision>
4. Greg Welch, Gary Bishop, “An Introduction to the Kalman Filter”, University of North Carolina at Chapel Hill Department of Computer Science